



MIDWEST Fasteners, Inc.
 450 Richard St. • Miamisburg, OH 45342
 www.midwestfasteners.com • email: sales@midwestfasteners.com
 Toll Free: 800/852-8352 • Fax: 937/866-4174

CD700

CAPACITOR DISCHARGE STUD WELDER



The **CD700** from Midwest Fasteners is designed specifically for the insulation contractor. In fact, it is one of the most powerful capacitor discharge units available today. The CD700 features a *separate cup head weld pin contact mode* that welds to materials as thin as 20 gauge – without fear of burn through. A unique feature is the 84,000 to 168,000 MFD *variable capacitance high/low power range switch* which handles the toughest applications. The high power range helps eliminate surface preparation when welding "Power Tip" pins from Midwest Fasteners.

The unit's *solid state circuitry* lowers maintenance costs, since moving parts are eliminated. And the *rugged steel chassis* makes the CD700 able to withstand the rigors of construction jobsites. Gauges and control knobs are protected by a *recessed control panel*. *Circuit breaker protection* prevents expensive repair to component

parts, such as printed circuit board. The *auto fault shut off* adds to operator safety, and the *panel meter* displays capacitor discharge voltage at a glance.

An *ultra-light 24 ounce Precision Contact Gun* is included with the CD700 system. With this gun, operator fatigue is reduced – thereby increasing production. The weld gun also features *interchangeable main spring pressure* that is necessary for many special welding applications, and critical in welding aluminum fasteners and dissimilar materials. The unique *drilled through gun shaft* enables precise gun set up for welding aluminum pins and extra long CD weld pins.

The CD700. Available only from Midwest Fasteners – your complete source for insulation fastening.

CD700 CAPACITOR DISCHARGE WELDING SYSTEM

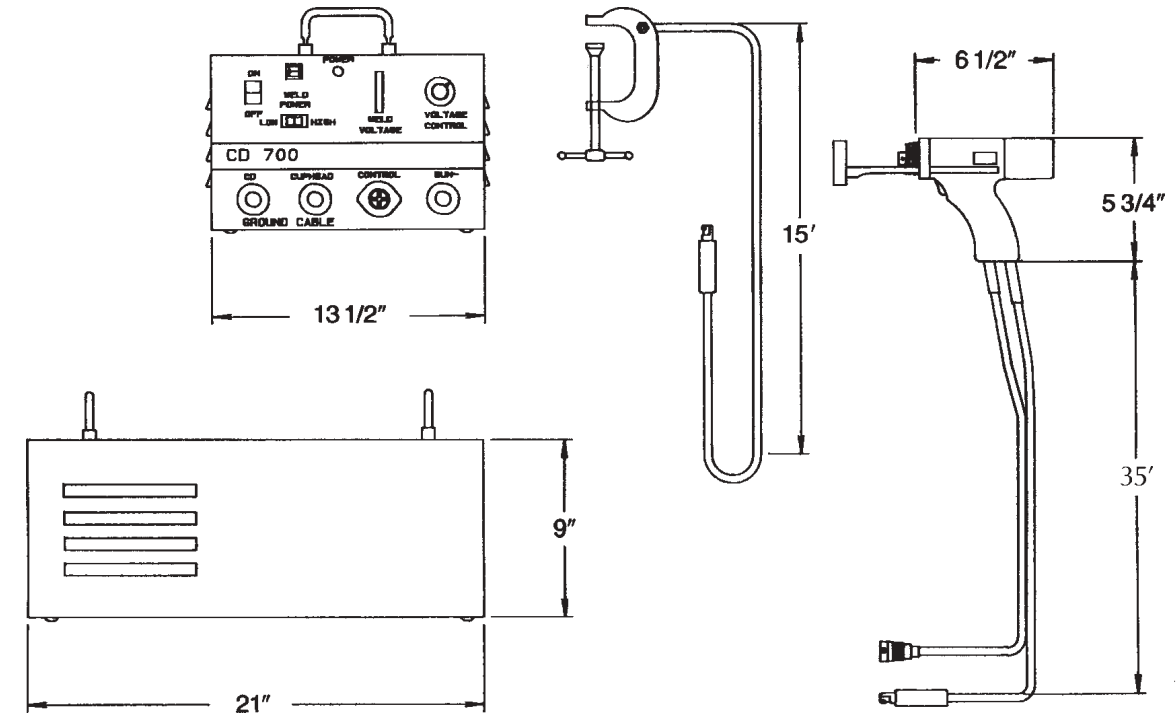

SPECIFICATIONS:

POWER SUPPLY/CONTROLLER

Height	9"
Width	13-1/2"
Depth	21"
Weight	66 Pounds
Capacitance	Low - 84,000 mfd High - 168,000 mfd up to 14/Min.
Weld Rate	
Weldable Materials	Mild Steel, Stainless Steel, Aluminium
Pin/Stud Range	14 Ga, thru 3/8" Dia. weld base
Weld Voltage	34-175 VDC
Weld Mode	Contact, Cuphead
Power Requirement	115VAC, 60 Hz, 30 Amp

WELD GUN (CD-2P PRECISION)

Weight	1-1/2 Lbs. (Not including cable)
Size (LWH)	6-1/2" x 2" x 5-3/4"
Weldable Dia.	14 Gauge through 3/8" Dia.
Material	High strength, impact resistance, polycarbonate

CABLES

Ground Cable	#1 x 15 Ft. (one each)
Gun Extension Set	#1 x 18/2 x 35 Ft. (direct to gun)



MIDWEST Fasteners, Inc.
 450 Richard St. • Miamisburg, OH 45342
 www.midwestfasteners.com • email: sales@midwestfasteners.com
 Toll Free: 800/852-8352 • Fax: 937/866-4174