



CD 100

Solid State

Capacitor Discharge Stud Welding System

Owner's Manual

- Installation
- Operation
- Maintenance



©2004 **MIDWEST FASTENERS, INC.**, all rights reserved.
450 Richard Street
Miamisburg, OH 45342
Phone: (800) 852-8352
Fax: (937) 866-4174

TABLE OF CONTENTS

GENERAL	Warranty	4
	Safety Precautions	5
INTRODUCTION	What is Stud Welding?	6
	How Does CD Stud Welding Differ From ARC Stud Welding?	6
	CD 100 Overview	8
INSTALLATION	CD 100 Installation	9
SETUP & OPERATION	CD 100 Setup	10
	Gun Set Ups	
	Insulation Pins	11
	Insulation Pins with Internal Stop	11
	Weld Studs	12
	Weld Studs with Template Adaptor	12
	Controller Adjustment	13
	Making A Test Weld	13
	Weld Quality	14
	Preventive Maintenance	15
MAINTENANCE	Troubleshooting	15
TROUBLESHOOTING	CD 100 Welder Specifications	18
SPECIFICATIONS	CD 100 Welder Exploded View & Parts List	19
	CD 2P Gun Specifications	20
	CD 2P Gun Exploded View & Parts List	21
	CD 100 Electrical Schematic	22
	Notes	23

WARRANTY

All parts used in the assembly of your MIDWEST FASTENERS Stud Welding System are fully guaranteed for Ninety (90) days from delivery date. In addition, the Welding Capacitors are fully guaranteed for a period of One Hundred and Twenty (120) days from delivery date.

Under this warranty, MIDWEST FASTENERS reserves the right to repair or replace, at its option, defects in material or workmanship which occur during the warranty period. Notice of any claim for warranty repair must be furnished to MIDWEST FASTENERS within ten (10) days after the defect is discovered. MIDWEST FASTENERS does not assume liability for shipping, or liability for any labor or material related to use of this system unless such costs are expressly authorized in writing by MIDWEST FASTENERS.

MIDWEST FASTENERS, INC. does not warrant defects in welders, parts or accessories resulting, from abuse, improper installation, or for reasons beyond its control.

This warranty is valid only when welding pins and/or studs approved by or purchased from MIDWEST FASTENERS.

MODEL NO.

SERIAL NO.

SHIPPING DATE

VOLTAGE REQUIRED

SAFETY PRECAUTIONS



- Comply with all electrical, fire and other applicable codes or ordinances in the installation and use of stud welding systems.
- Remove all combustible or volatile materials from the weld area. Although weld splatter resulting from stud welding is normally minimal, proper precautions should be taken when welding near or through combustible materials to insure that sparks or weld material do not come in contact with combustible material.
- Recommend wearing of eye protection at all times when welding. Spectacle type frames with Shade No. 3 absorptive and filter lens and side shields are suggested. Never look directly at the weld arc without wearing eye shields.
- Recommend use of proper ear protection with all CAPACITOR DISCHARGE stud welding systems. The stud welding operator and anyone working within five (5) feet of the stud welding operation should use ear protection devices.
- Use of protective clothing is suggested. Type of clothing will vary as to application, weld position and stud welding being used; however, in all cases, it should be fire resistant and sufficient to protect welding operator from weld splatter and material.
- Keep hands, clothing, etc. away from the weld stud, chuck and all other parts in contact with them during the weld cycle.
- Keep weld cable and connectors in good condition. Inspect periodically for broken insulation and/or other electrical hazards.
- Do not operate with worn or poorly connected cables. Inspect all cables often for bare or exposed wires, broken insulation layers and/or loose connections. Repair all such connections before welding use.
- Do not stand in water or on damp surfaces while welding. Avoid wearing wet or sweaty clothes. Do not weld in the rain.

WARNING

Use extreme caution when servicing or troubleshooting any component of this stud welding system. If possible, turn all power controls **“OFF”** and disconnect all electrical cables.

For other suggested precautions, safe practices, etc. regarding welding, refer to “Safety in Welding and Cutting”, ANSI Z49.1, American National Standards Institute.

WHAT IS STUD WELDING?

Stud welding is a welding process where a “stud” (or similar metal part) is instantaneously end-joined to a metal workpiece. This process involves the same basic principles and metallurgical aspects as any other welding process.

The equipment required to stud weld is composed of a direct current power supply, a controller, a weld gun and cables to tie the system components together. In most systems the power supply and controller are combined into one unit called the “Welder.”

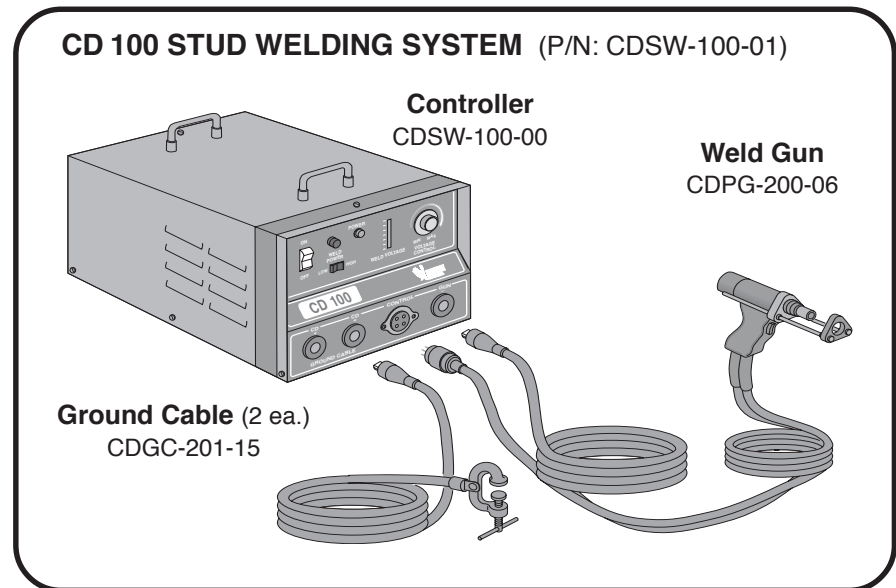

The stud welding process is as follows. The stud is placed in the collet of the “Weld Gun” and then positioned against the workpiece. The weld gun trigger is depressed and through operation of the stud welding controller and the design of the stud, an arc is drawn which melts the base of the stud and a proportionate area of the workpiece. The stud is then forced by the weld gun into the molten pool and held in place until the metals resolidify. This high quality fusion weld is completed in milliseconds.

HOW DOES CD STUD WELDING DIFFER FROM ARC STUD WELDING?

There are two different stud welding processes:

- **Capacitor Discharge** (called “CD” for brevity) and
- **Arc.**

The difference between these two methods involves the power source used to provide the welding current, the workpiece size, base material and the stud design.

CD STUD WELDING

The CD stud welding process produces weld power through a rapid discharge of the stored energy from a bank of capacitors. This stored energy is usually derived from a standard 115 volt AC source. CD stud welding, as a general rule, is used for studs 5/16" and less in diameter, (or where thin base metals or dissimilar metals are to be joined.)

"CD" STUD WELDING PROCESS

1. Stud is placed against workpiece and weld gun trigger depressed

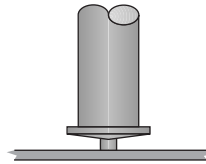

2. Stored energy is discharged through special tip

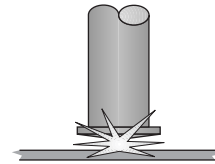

3. Weld gun forces stud into molten metal

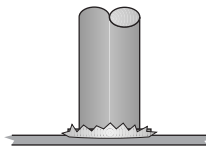

4. Weld solidifies in milliseconds

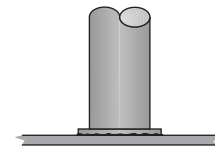

ARC STUD WELDING

The ARC stud welding process produces weld power through one of three standard DC welding power sources. These are Transformer-Rectifier type, Motor/Generator type, or Storage Battery type. A ceramic ferrule is required in ARC stud welding to maintain the proper atmosphere in the weld area. ARC stud welding is generally used for studs over 1/4" in diameter or where heavier base metals are involved.

"ARC" STUD WELDING PROCESS

1. Stud is placed against workpiece and weld gun trigger depressed

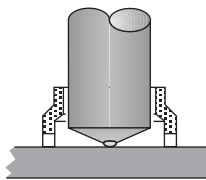

2. Stud is lifted by weld gun and initiating arc is drawn

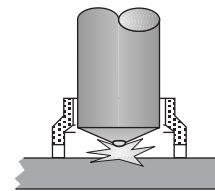

3. Weld gun forces stud into molten metal

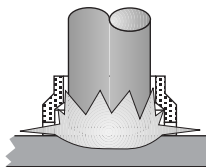

4. Weld solidifies and ferrule is removed

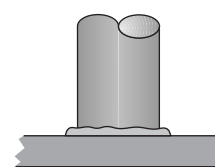

OVERVIEW – CD 100 CAPACITOR DISCHARGE STUD WELDER

The CD 100 is a capacitor discharge stud welder. The weld energy is stored in capacitors located inside the control unit. The amount of stored energy can be controlled by rotating the voltage control knob located on the front panel.

CD weld studs, or pins, used with the CD 100 must have a specially designed projection at the weld end. When the stud is inserted into the weld gun and placed against the workpiece, and the trigger switch is depressed, the following occurs:

1. The energy stored in the capacitors travels through the weld cables to the stud.
2. The rapid rise in current ignites the projection and allows a welding arc to be established between the stud and the workpiece.
3. The arc melts the base of the stud and a portion of the workpiece.
4. The spring pressure inside the welding gun forces the stud into the molten metal pool created by the arc.
5. The cycle ends upon contact of the stud to the workpiece.
6. The welding gun is then removed. Upon removal, the controller will automatically recharge to the set voltage.



CAUTION

The **noise** generated by stud welding may exceed allowable levels established by O.S.H.A. For this reason it is recommended that proper ear protection be worn by the operator and anyone working in the immediate area.

WARNING

Voltages inside the unit can reach 200 volts D.C. *even if the unit is turned off.* All repair work should be handled by factory trained personnel.

CD 100 INSTALLATION

Follow the process below to properly install your CD 100 stud welder.

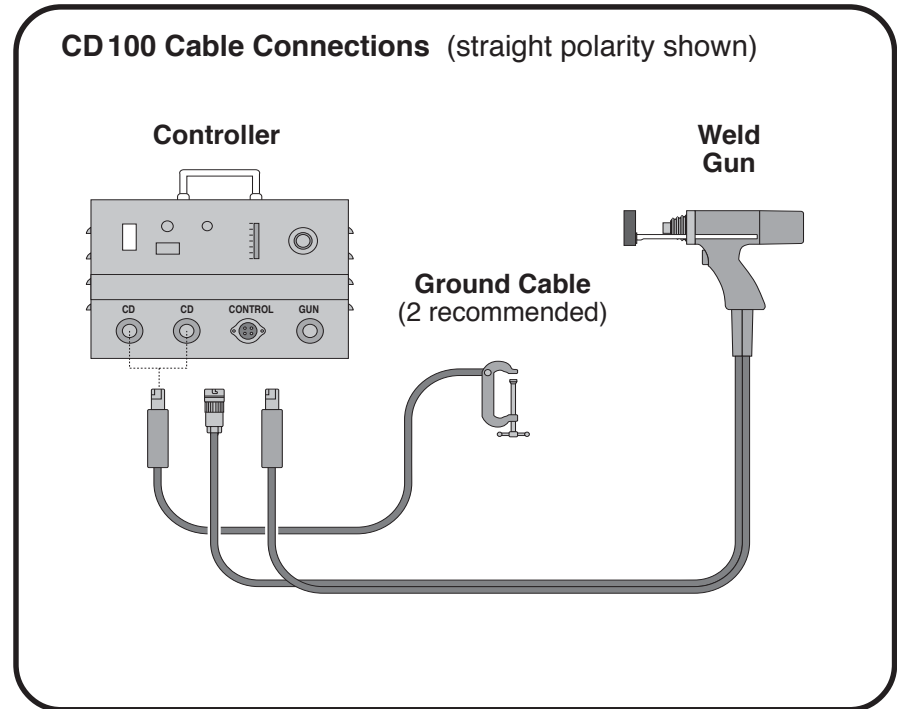

NOTE: All cables should be laid out straight or in large loops. Poor welds may result if welding cables are closely coiled or stacked up.

1. Carefully remove the controller, cables and weld gun from the shipping packaging.
2. Set the **Controller** on a clean, dry, sturdy surface near an appropriate voltage supply and the workpiece.
3. Connect the **Ground Cable** male cam-lok connector to the controller connector marked “CD / GROUND CABLE” for each of two (2) recommended ground cables.
4. Clamp the **Ground Cable** C-clamp firmly to a clean (free from paint, rust, scale, grease or oil) area on the workpiece. Using the two (2) recommended ground cables, surround the area to be welded.
5. Connect the **Gun Cable** male cam-lok connector to the Controller receptacle marked “GUN.”
6. Connect the **Gun Cable** control connector to the Controller receptacle marked “CONTROL.”
7. Plug the Controller Power Cord to appropriate power source.

CD 100 SETUP

After installation, two setup phases must be completed before welding can begin. These phases are:

- **Weld Gun Setup**, and
- **Controller Adjustment**.

WELD GUN SETUP

Your weld gun setup will depend on your application and the particular stud to be welded. Setting up the gun consists of the following:

1. Locate the pins (or studs) that were shipped for your job and place a pin into the weld gun Collet with the “weld tip” protruding. Push this pin in until it seats firmly, assuring that the flange (or collar) of the weld end does not come into contact with the collet.
2. Make sure that the gun “setup” accessories that came with the CD 2P weld gun are adjusted properly and fastened tightly. Illustrations on the following pages for:
 - Insulation Pins (Figure 1)
 - Insulation Pins with Internal Stop (Figure 2)
 - Weld Studs (Figure 3)
 - Weld Studs with Template Adaptor (Figure 4)

NOTE: These components may need to be readjusted, or changed, as your job requirements change.

CD-2P WELD GUN SETUP

INSULATION PINS

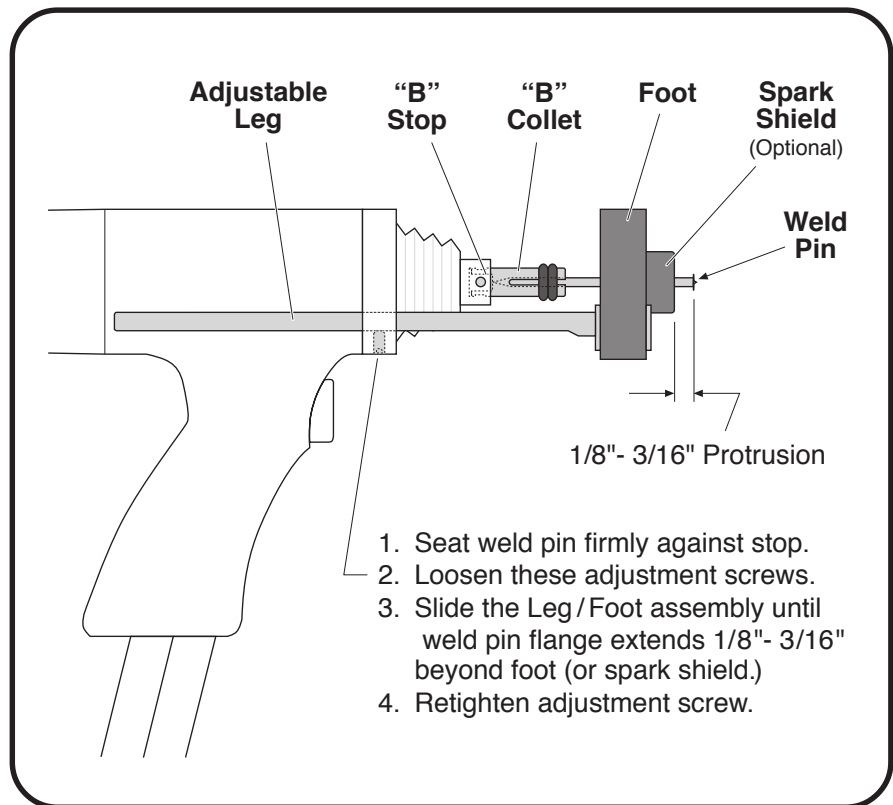

(Fig.1)

CD-2P WELD GUN SETUP

INSULATION PINS

WITH

INTERNAL STOP

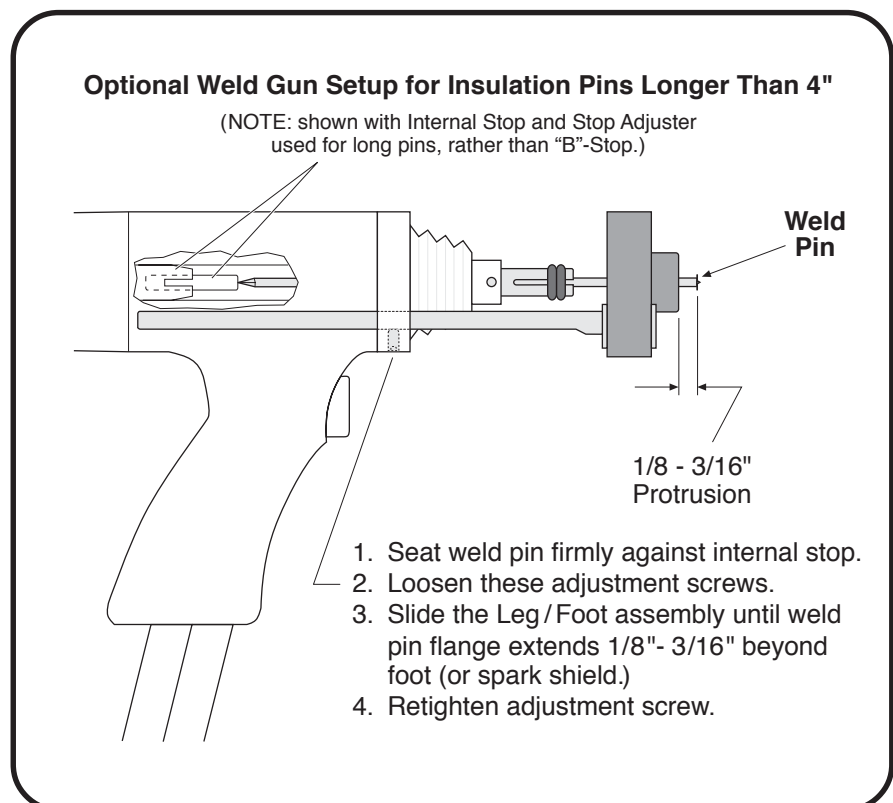

(Fig.2)

**CD-2P WELD GUN
SETUP**

WELD STUDS

**CD-2P WELD GUN
SETUP**

WELD STUDS

WITH

TEMPLATE ADAPTOR

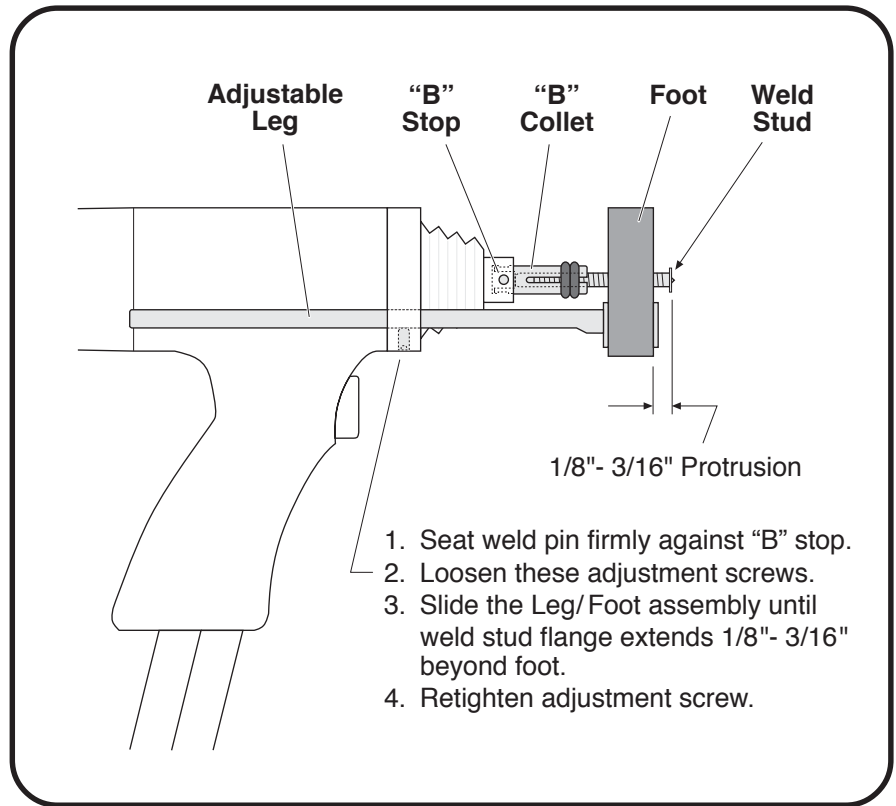

(Fig.3)

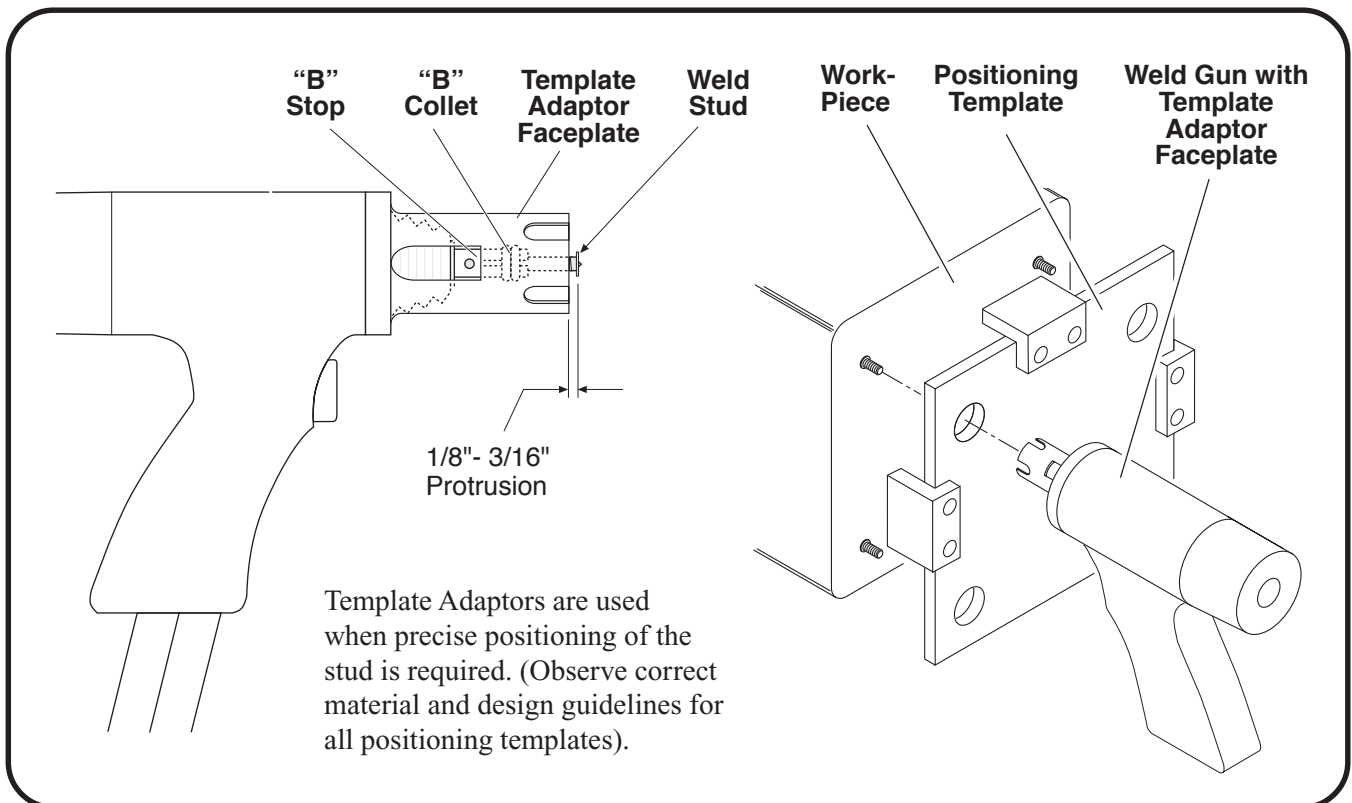

(Fig.4)

CD 100 SETUP - CONTROLLER ADJUSTMENT & MAKING A TEST WELD

After verifying that the welding system is installed and your weld gun is setup properly for your application, the final step is to adjust your stud welding controller to the proper settings.

1. (Before turning on power) turn the controller **VOLTAGE** selector switch to “**MIN**” (fully counterclockwise.)
2. Turn the controller **ON/OFF** switch to “**ON**.” Verify by observing “**POWER**” lamp.
3. Using the chart below, adjust the “**VOLTAGE**” control until the “**WELD VOLTAGE**” meter reads the desired value.

The chart settings shown below are "reference" settings to be used as starting points. Actual voltage settings may vary depending upon the conditions or each application and use. The voltages shown also assume that the following are in use (as described in previous Installation and Setup sections of this manual.)

- A) Straight polarity cable set ups in use (Gun = Negative, Ground = Positive.)
- B) Ground connection directly to the part to be welded and connected in a clean, solid manner.
- C) 1/8" protrusion of pin/stud onto work (3/16" for Aluminum) causing an equal amount of spring pressure in the gun.
- D) “Black” spring is standard in CD2P "Precision" Weld Gun as supplied with CD100 systems. Optional/interchangeable gun springs, for weld pressure changes, are available.
- E) Good, clean accessories and work surface to be welded, with proper setup of all accessories.

Pin/Stud Type	Pin/Stud Dia	Pin/Stud Mat'l.	Tap	Voltage Setting
Insulation Pin	12 GA	Mild Steel or Stainless	Low	90-100
	10 GA		Low	100-110
	12 GA	Aluminum	Low	120-130
	10 GA		Low	135-145
Weld Studs (Flanged)	#10 or 3/16"	Mild Steel or Stainless	Low	125-135
	1/4"		Low	135-145
	5/16"		High	145-155
	3/8"		High	155-165
	#8	Aluminum	Low	120-130
	#10 or 3/16"		Low	130-140
	1/4"		High	140-150
	5/16"		High	150-160

NOTE: Be sure that proper observation of all safety precautions are in place before performing the next step.

4. Pick up the weld gun and place the stud firmly against the workpiece (The test workpiece should be a material that is similar to the workpiece to be welded to in actual production.)
5. Depress the weld gun trigger, wait momentarily, and then pull the gun straight back off the stud.
6. Test the weld integrity (see below.)

WELD QUALITY

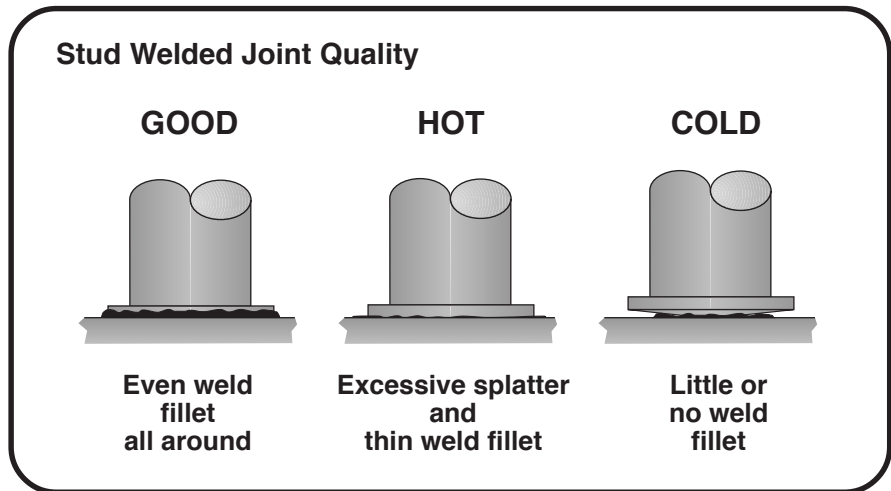

- A **GOOD** weld is determined by bending the stud back and forth. Failure should occur in the stud shank or workpiece, not in the weld.
- **HOT** weld shows excessive splatter — adjust voltage downward (see 7. A. below).
- **COLD** weld shows little or no splatter and may have a void between the stud and workpiece — adjust voltage upwards. (see 7. B. below).

If you need assistance with setup, or operation, call **MIDWEST FASTENERS** Technical Support at (800) 852-8352 Monday through Friday between 8am and 5pm Eastern time.

7. Adjust the weld voltage up or down until a satisfactory weld is consistently achieved.
 - A. When adjusting voltage **downward**, (e.g. from 100 V to 80 V) it is necessary to turn the power off. Then turn the voltage selector knob counterclockwise, turn the power back on, and increase to the required voltage.
 - B. To adjust the voltage **upwards** (increase weld heat), turn the voltage selector knob clockwise in small increments to a higher setting.

When weld quality is consistently satisfactory, the CD 100 is properly installed and setup.

PREVENTATIVE MAINTENANCE

Your MIDWEST FASTENERS welder is designed for long service with minimal care. Ordinary common sense maintenance will keep it operating efficiently. The following are a few tips on preventive maintenance.

1. Treat the cables with respect. Avoid sharp bends or kinks which may break the cables. **DO NOT** use the cables as a “towline” to drag or lift the controller. Avoid damaging or straining the cables where they enter the gun or controller.
2. Louvers on the sides of the controller should be free from obstructions at all times to prevent overheating.
3. Keep the controller and gun clean and dry, free of grease, water, dust and dirt. Do not lubricate any part of your CD 2P weld gun.
4. The weld gun is for welding studs only. Do not use the weld gun as a multipurpose tool (i.e., Hammer—banging studs to test welds or break ferrules, Scraper—removing rust, scale or weld splatter, etc.)

TROUBLESHOOTING

When troubleshooting the CD 100, the following precautions must be observed.

1. Controller power must be **TURNED OFF!**

NOTE: Dangerous voltage levels can still be present in the controller—even after power is disconnected.



HIGH VOLTAGE

2. The use of a volt/ohmmeter is recommended to verify where any voltage may, or may not, be present.
3. The use of a continuity tester (or trouble shooting light) can be used for continuity checking (disconnected) cables only.

The troubleshooting chart on the following pages can assist in locating and fixing problems with the CD 100.

TROUBLESHOOTING CHART

PROBLEM	POSSIBLE CAUSE	CORRECTIVE ACTION
1. Welder does not turn on and will not weld.	A. Power cable connection at controller or 115 VAC outlet not complete.	Inspect power cable connection. Repair if loose.
	B. Power cable/connector damaged.	Check for continuity. Repair break or replace connector.
	C. Open circuit breaker, fuse or damaged wall outlet.	Check with ohmmeter. Replace defective part (Fuse = BUSS MDA30, or equivalent.)
2. Circuit Breaker trips or fuse blows each time the controller is turned on.	A. Shorted weld capacitor.	Check capacitors safety vent seal for rupture hole. Replace defective capacitor.
	B. Shorted rectifier.	Check with ohmmeter. Replace rectifier if defective.
	C. Faulty circuit breaker.	Check with ohmmeter. Replace rectifier if defective.
	D. Shorted transformer.	Remove two orange wires from charge rectifier. If fuse continues to blow, replace transformer.
3. Circuit Breaker trips or fuse blows when weld is made.	A. Shorted charge SCR.	Check with ohmmeter. (Should not show continuity in either direction.) Replace if defective.
	B. Faulty printed circuit (PC) board.	Replace with new PC board if defective.
4. Welder powers on, but does not operate.	A. Ground cable or gun cable connections not complete.	Check for continuity and proper connection of ground to workpiece.
	B. Broken gun control cable or loose wire connection in plug.	Check continuity between pins “+” and “Z” of plug while depressing gun trigger. Should read continuity only when depressed.
	C. Shorted gun control wires at the gun trigger switch.	Check continuity between pins “+” and “Z” of plug. No reading should be observed while gun trigger is in the released position.
	D. Faulty printed circuit board.	Replace with new PC board if defective.

TROUBLESHOOTING CHART

PROBLEM	POSSIBLE CAUSE	CORRECTIVE ACTION
4. Welder powers on, but does not operate. (continued)	E. Shorted weld SCR.	Unplug PC Board and check continuity between SCR heat sink and negative (-) buss bar. No reading should be observed. Replace SCR if continuity exists.
5. Weld is excessively hot regardless of voltage setting.	A. Shorted charge SCR.	Check continuity across SCR. No reading should be observed in either direction. Replace charge SCR if continuity exists.
	B. Faulty printed circuit board.	Replace with new PC board if defective.
	C. Open voltage potentiometer.	Replace defective voltage potentiometer.
6. Consistently poor or erratic welds.	A. Improper gun setup.	Check gun for proper setup (see page 10).
	B. Improper grounding, cable installation or incorrect polarity.	Check grounding and cable installation for proper setup (see page 9).
	C. Weld cables coiled.	Straighten out cables or place in random loops.
	D. Incorrect weld voltage setting.	Adjust as necessary (see page 13).
	E. Studs (or Pins) not perpendicular to workpiece.	Adjust gun set up as necessary. Replace bent or defective legs (see page 10).
	F. Faulty printed circuit board.	Replace with new PC board if defective.

If you need assistance with setup, or operation, call **MIDWEST FASTENERS** Technical Support at (800) 852-8352 Monday through Friday between 8am and 5pm Eastern time.

CD 100 STUD WELDING SYSTEM SPECIFICATIONS

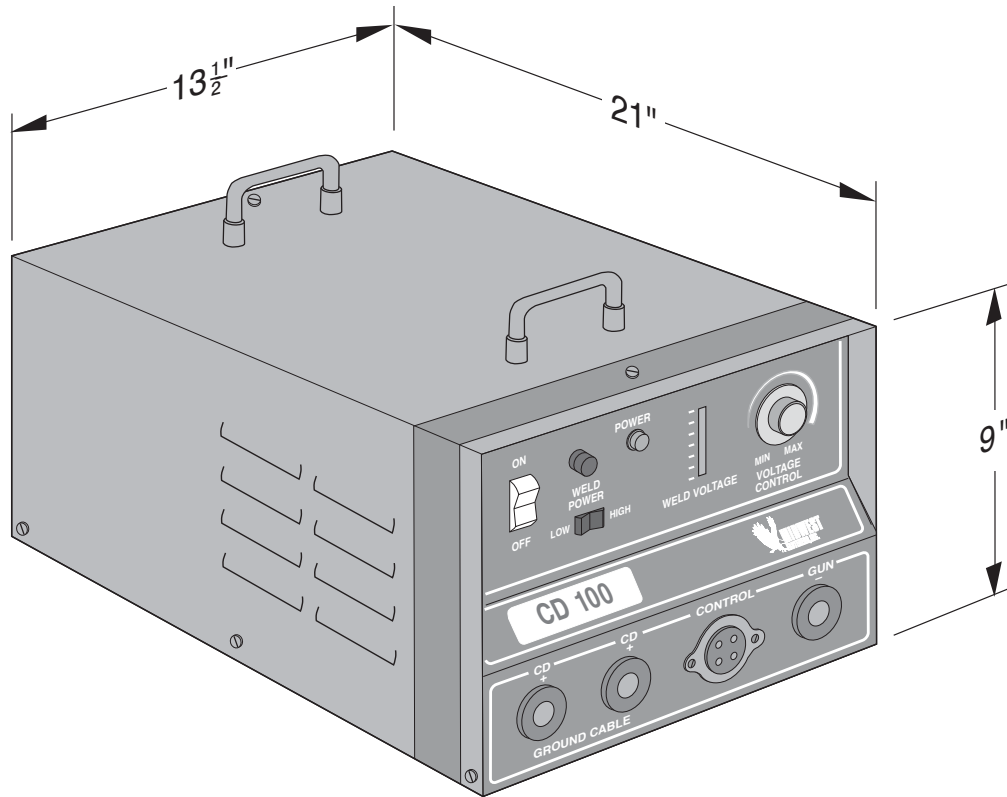

- Weight 66 pounds
- Power Requirement 115 VAC, 60 Hz, 30 Amp
- Pin/Stud Range 14 ga. – 3/8" dia.
- Weldable Materials Mild Steel, Stainless,
& Aluminum
- Weld Modes Contact
- Weld Rate 14/minute (maximum)*
(* Dependent on stud size.)
- Weld Voltage 34–175 VDC
- Capacitance - Low 84,000 mfd
- High 168,000 mfd
- Cables 15' Ground Cable (2 supplied/recommended)
25' Extension Set (recommended minimum)

CD 100 STUD WELDING SYSTEM EXPLODED VIEW DIAGRAM & PARTS LIST

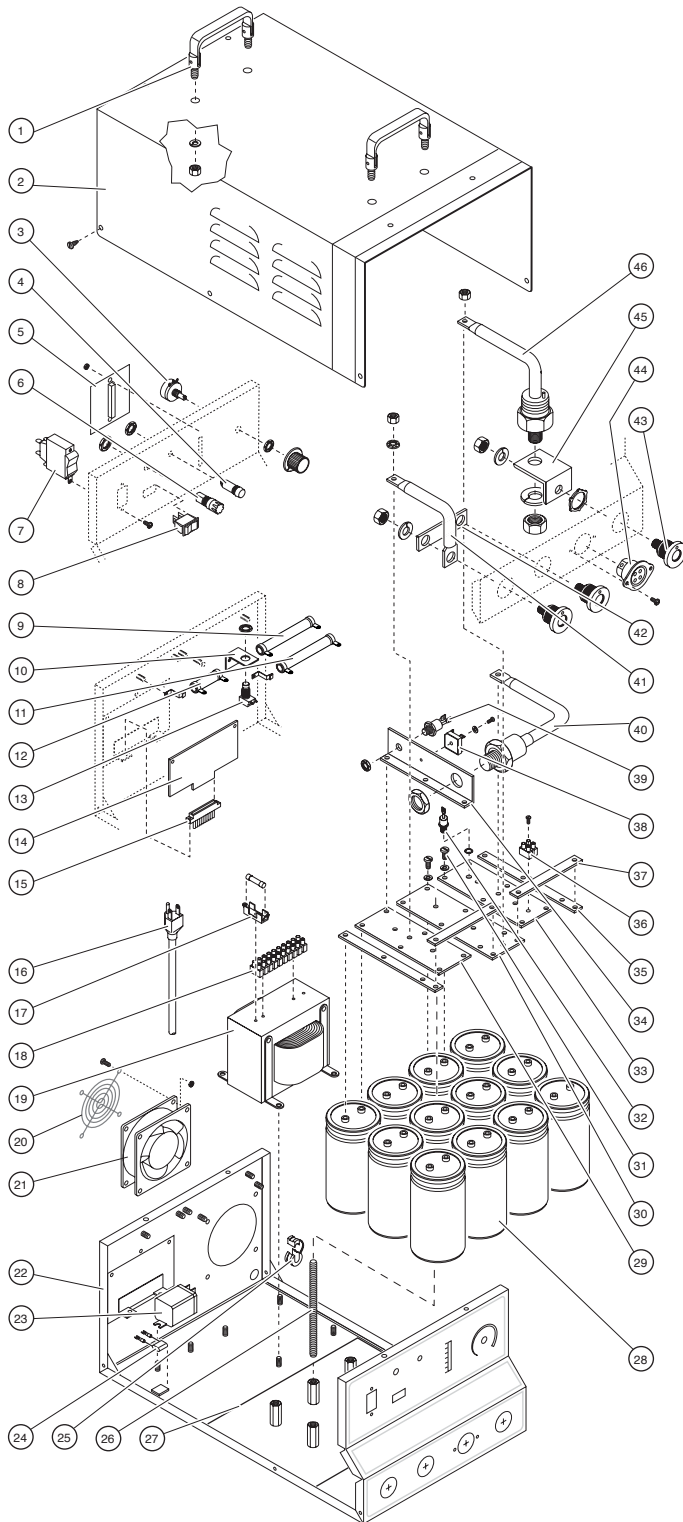

Item	Qt'y.	Part No.	Description
1	2	050-1004-93	Cabinet Handle
2	1	050-1002-54	Sheet Metal Cover
3	1	050-1003-16	Voltage Control Potentiometer
	1	050-1002-87	Voltage Control Knob
4	1	050-1004-78	Power Indicator Light
5	1	050-1005-06	Voltmeter LED
6	1	050-1001-06	Fuse Holder
	1	050-1001-03	30A Fuse
7	1	050-1004-01	Power Circuit Breaker Switch
8	1	050-1004-03	Hi/Lo Switch
9	1	050-1003-54	Bleed-Off Resistor
10	1	050-1001-15	Safety Switch Bracket
11	1	050-1003-55	Current Limiting Resistor
12	1	050-1003-53	Ballast Resistor
13	1	050-1004-02	Cabinet Safety Switch
14	1	060-3081-01	PC Board Assembly
15	1	050-1002-80	Wiring Harness Assembly
16	1	050-1004-74	Power Cord
17	1	050-1001-05	Fuse Holder
	1	050-1001-01	Fuse 1A
18	1	050-1004-16	Terminal Strip
19	1	050-1002-66	Main Transformer
20	1	050-1004-95	Fan Guard
21	1	050-1004-85	Fan
22	1	050-1002-24	Sheet Metal Base
23	1	050-1003-32	Bleed-Off Relay
24	1	050-1002-02	Snubber Capacitor
25	1	050-1004-83	Cable Grommet - AC
26	6	181-1100-58	Hold Down Rod
27	1	050-1005-05	Capacitor Insulator 100/700
28	12	050-1002-01	Weld Capacitor
29	2	050-1001-80	Bus Bar - B
30	1	050-1001-85	Bus Bar - G
31	24	181-3029-01	10-32 x 5/8 Pan Head Screw
	24	181-1260-01	#10 Split Lock Washer
32	1	050-1001-33	Steering Diode
33	1	050-1001-80	Bus Bar - B
34	1	050-1001-25	Diode Bus Bar
35	2	050-1001-84	Bus Bar - F
36	1	050-1004-41	Terminal Strip - Gate
37	2	050-1001-82	Bus Bar - D
38	1	060-1009-01	Charge Bridge Rectifier
39	1	050-1003-72	Charge SCR
40	1	050-1001-32	Welding Diode
41	1	050-1004-98	Internal Weld Cable
42	1	050-1005-01	Jumper Bar
43	3	060-3068-00	Camlok Connector Receptacle
44	1	050-1002-35	Control Connector Receptacle (PM-F)
45	1	050-1001-16	SCR Heat Sink Bracket
46	1	050-1003-73	Main SCR
	1	050-1001-62	Data Plate <i>(Not shown)</i>
	6	050-1004-80	Resistor Mounting Bracket <i>(Not shown)</i>

CD 2P STUD WELDING GUN SPECIFICATIONS

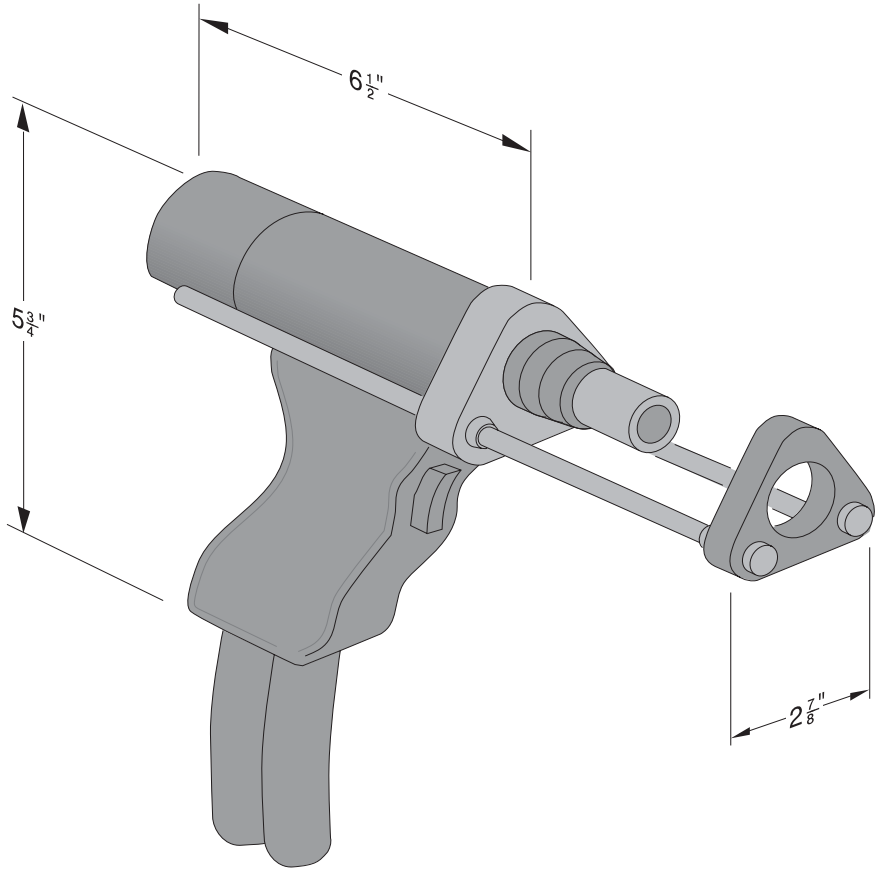

- Weight 1-1/2 pounds
(not including cables)
- Pin/Stud Range 14 ga. – 3/8" dia.
- Weldable Materials Mild Steel, Stainless,
Brass & Aluminum
- Material High strength, impact
resistant, polycarbonate
- Cable Length 6'

CD 2P STUD WELDING GUN EXPLODED VIEW DIAGRAM & PARTS LIST

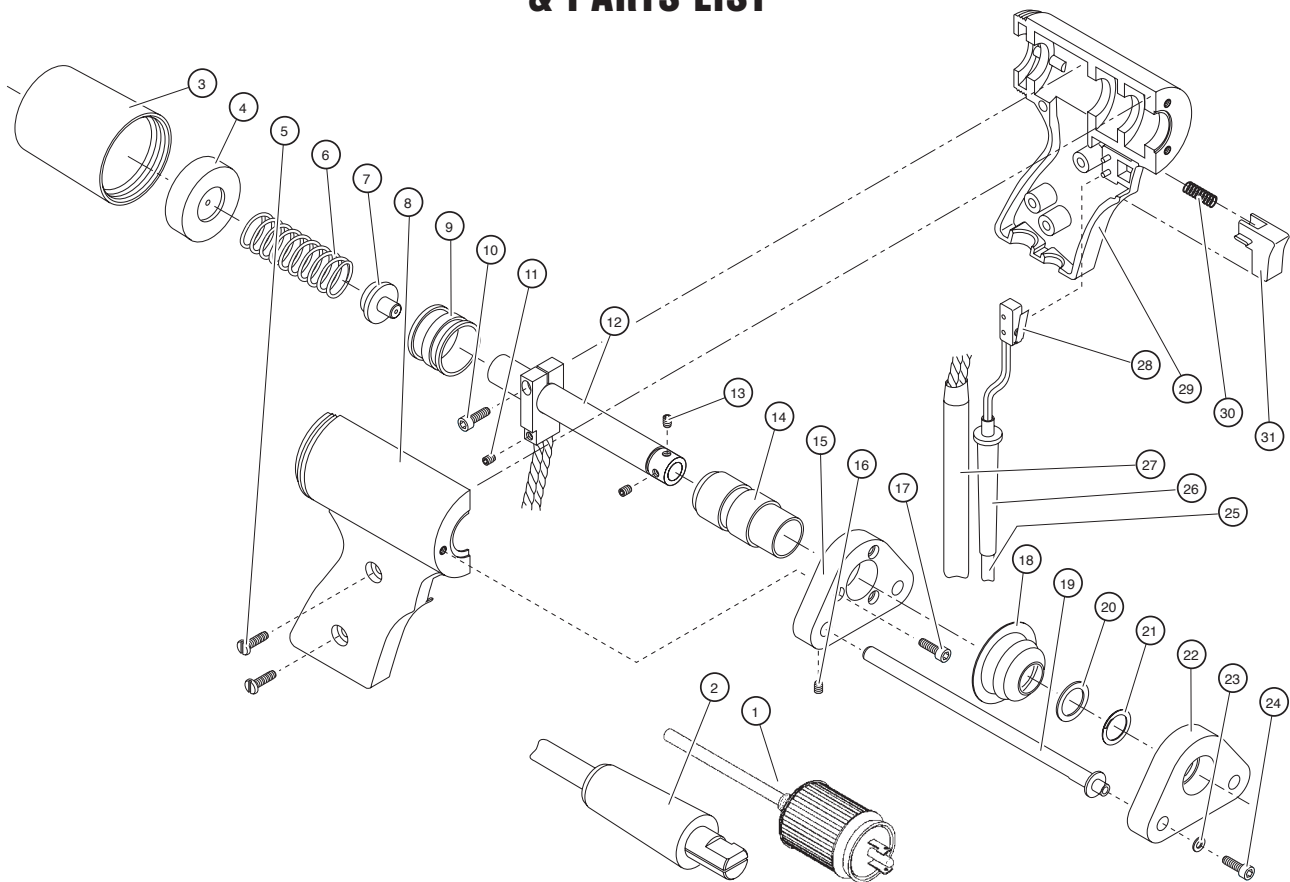

Item	Qt'y.	Part No.	Description
1	1	050-1002-36	Male Control Connector
2	1	060-3046-00	Male Weld Connector
3	1	050-1005-34	Rear Body Cap
4	1	050-1005-43	Spring Retaining Plate
5	2	181-3029-01	10-32 x 5/8 Pan Head Screw
6	1	060-3010-03	Shaft Spring (Black)
7	1	050-1005-41	Spring Retainer Plug (Prec.)
8	1	050-1005-32	Right Gun Body Half, Precision
9	1	050-1003-92	Shaft Tube Bearing - Rear
10	1	181-3029-19	10-32 x 5/8 Soc Head Screw
11	1	181-3029-20	10-32 x 3/16 Set screw
12	1	060-3029-00	Gun Shaft
13	2	181-3029-20	10-32 x 3/16 Set Screw
14	1	050-1003-94	Front Shaft Bearing
15	1	101-0601-00	Standard Faceplate
16	2	181-3029-20	10-32 x 3/16 Set Screw
17	3	181-3029-18	8-32 x 3/4 Soc Head Screw
18	1	060-3221-00	Shaft Boot
19	2	101-0801-01	Weld Gun Leg 7"
20	1	060-3222-07	Boot Retainer
21	1	060-3222-06	Boot Retainer Split Ring

Item	Qt'y.	Part No.	Description
22	1	101-0701-00	Weld Gun Foot
23	2	181-1260-39	#10 Flat Washer
24	2	181-3029-19	10-32 x 5/8 Soc Head Screw
25	1	050-1005-48	Control Cable
26	1	050-1005-47	Rubber Cable Sleeve, Small
27	1	056-2001-14	Weld Cable Assembly
28	1	060-3053-00	Trigger Micro Switch
29	1	050-1005-33	Left Gun Body Half, Precision
30	1	060-3003-00	Trigger Button Spring
31	1	050-1005-35	Trigger Button
			<i>Not Shown</i>
		060-3010-01	Shaft Spring (Silver)
		060-3010-02	Shaft Spring (Gold)
		060-3010-04	Shaft Spring (Copper)
		060-3010-05	Shaft Spring (Red)

CD 100 STUD WELDING SYSTEM ELECTRICAL SCHEMATIC

